



Operable partition systems from
Dessau – the Bauhaus City





HUFCOR CONTENTS

HUFCOR	8-9
HUFCOR TYPE 100 100K	10-13
HUFCOR moVISTA	14-17
PANEL TYPES / TECHNICAL DETAILS	18
LOCKING SYSTEMS	19
HUFCOR GLASS WALL PARTITIONS G3000	20-25
TRACK SYSTEMS / PARKING POSITIONS	26-29
SURFACES	30-33
CERTIFICATION / REPRESENTATIVE PROJECTS	34-35



CREATIVITY CREATES SPACES

HUFCOR

CREATIVITY CREATES SPACES

In 1996, HUFCOR Inc, Janesville, WI – the world leader in flexible space management – established a subsidiary in Germany, Europe's largest market for operable partitions. The selected location is the venerable World Cultural Heritage and Bauhaus City of Dessau. Gropius, Junkers and Kurt Weill are but a few world-renowned personalities who lived and worked in Dessau.

Production of patented Hufcor partitions commenced here in 1997. In the meantime, HUFCOR Deutschland GmbH is among the market leaders in Germany. Thousands of custom-designed panels are fabricated, delivered and installed every year.

The German market is serviced by professionally-trained space management consultants. Our team members will identify and prepare project-specific solutions jointly with you.

Well-trained and highly-motivated craftsmen, sales consultants and certified installation contractors, high product qualities, investments and innovations as well as our excellent after-sales service are the basis of our continuous growth. Smooth order processing is one of our strengths.

HUFCOR Deutschland GmbH is investing millions of euros on a manufacturing plant expansion, new machinery and equipment and upgraded software in order to meet the high demand and continued our success story.

HUFCOR Manufacturers:



USA: Janesville
HUFCOR Inc.



AUSTRALIA: Victoria
HUFCOR PTY Ltd.



ENGLAND: Derbyshire
HUFCOR UK Ltd.



GERMANY: Dessau
HUFCOR Deutschland GmbH



MALAYSIA: Kuala Lumpur
HUFCOR Maroshumi SDN BHD



MEXICO: Estado de Mexico
Hufcor Airwall S de RL de CV



CHINA: Hong Kong
HUFCOR Asia Pacific Ltd.

HUFCOR Licensees:



BRAZIL: Novo Hamburgo
HUFCOR do Brasil LTDA



CANADA: La Prairie
Corflex Partitions Inc.



JAPAN: Komatsu Ishikawa
Komatsu Wall Industry Co.



RUSSIA: Moscow
NAYADA PARTITION SYSTEMS



SOUTH AFRICA: Durban
Pelican Systems Limited



SPAIN: Barcelona
Reiter System S.A.



UNITED ARAB EMIRATES: Ajman
GIBCA Furniture Ind. Co. Ltd.

HUFCOR Resellers:

Worldwide in over 160 countries



HUFCOR TYPE 100 | 100K OPERABLE PARTITIONS

The uses of operable partitions are limitless: Hotels and convention centers, schools and kindergartens, banks and insurance firms, restaurants and student cafeterias, offices and conference rooms, gyms and dancing schools, community centers and auditoriums, shopping centers and museums, police and military training centers ...

HUFCOR operable partition systems should be your first choice when flexibility is your priority – a decision in favor of economic efficiency, product utility and customer value.

Distinguishing features of HUFCOR operable partitions include excellent quality and unparalleled, ease of movement. Our "Quick-Set" seal system is by far the swiftest and easiest way to manually operate partitions on the market today.

The broad range of overhead precision aligned aluminum tracks-free, ball-bearing rollers are becoming the preferred choice of numerous prestigious customer.

This innovative technology has earned the HUFCOR Group key supplier status of leading hotel chains. HUFCOR operable partitions have more than 6000 worldwide hotels systems installed throughout 115 countries.

Are you aware of any other manufacturers of operable partitions who can provide similar references?



HUFCOR TYPE 100 | 100K OPERABLE PARTITIONS

- 3 S "Quick-Set" mechanical locking seal system
 - Fast locking by a mere half turn
 - Stable due to high contact pressure
 - Safe through verified quality (TÜV)
- Smooth-running, extremely low-noise aluminum track system with ball-bearing-supported, wear-free Delrin® castors
- Low weight due to reinforced bolted aluminum frame
- ESS – all panels also with electric-driven sealing bar
- EI30 fire resistance available for Type 100
- Certified sound control up to 57 dB Rwp [tested sound insulation factor]
- Tension-locked panel connection with magnet straps
- Stainless-steel door latches and stainless-steel hinge straps
- Unlimited decor options
- TÜV DIN 31000 General principles for the safe design of technical products
- DIN 18032-3 Testing of safety against ball throwing



Panel connection TYPE 100 with tension-locked magnetic section



Panel connection TYPE 100K with visible aluminum edge



Aluminum casing with circumferential steel frame



Low weight due to high-tensile bolted aluminum frames



User-friendly panel handle for easy panel unfastening



Finger pinch protection 180° up to door leave height for strap and counter-strap



Stainless-steel door latch (gymnasium door fitting)



Stainless-steel door straps and adjustable mechanism for bottom door sealing

HUFCOR moViSTA TRANSPARENCY COMBINED WITH SOUND CONTROL

Our operable glass movable wall, HUFCOR moViSTA, helps you provide aesthetic accents with sound performance. HUFCOR moViSTA allows both transparency and a high level of sound control – often two performance features that are contradictory

Slimline aluminum sections enable maximum light transmittance. Electronically controlled horizontal and vertical aluminum sealing systems enhance ease of use. Integrated magnetic sections ensure a tension locked panel connection. A safety circuit prevents unattended closure of the partition.

Combine glass moViSTA panels with solid wall panels and/or with pass doors and use the unlimited variety of our available decors. You create your designs – we implement your project.

Need Hufcor moViSTA panels with slatted blinds? No problem. Our engineers have developed a solution for this challenge to add privacy to the glass panels. moViSTA panels can include a remote control operator to rotate and turn the slats, including up & down movement into any desired position.

HUFCOR moViSTA movable wall are ideally suited to partition office spaces and conference rooms. But also in studios, community centers, hotels and schools, transparency and quietness ensure a pleasant, light-infused interior environment.

HUFCOR moViSTA partitions are an interior design highlight in any room decor.



HUFCOR moViSTA

TRANSPARENCY COMBINED WITH SOUND CONTROL

- Certified sound control up to 47 dB Rwp
- Aluminum sections in all RAL colors
- Unlimited combination options with any requested surface finish
- Remote-controlled slatted blinds in a large variety of colors
- Lever closure panels as glass panels
- Safety circuit with magnetic sensor
- Top & Bottom electrically activated seals extended in a matter of seconds
- Emergency battery powered operation
- Trouble-free motors 'Made in Germany'
- Panel height up to 4,00 m
- CE as defined in Machine Directive

HUFCOR MOVISTA PANELS COMBINED WITH SLATTED BLINDS



1 moViSTA Standard panel 2 Standard panel 3 Door panel 4 Lever closure panel

HUFCOR moViSTA AS FULL GLASS WALL PARTITION, INCL. LEVER CLOSURE GLASS PANEL

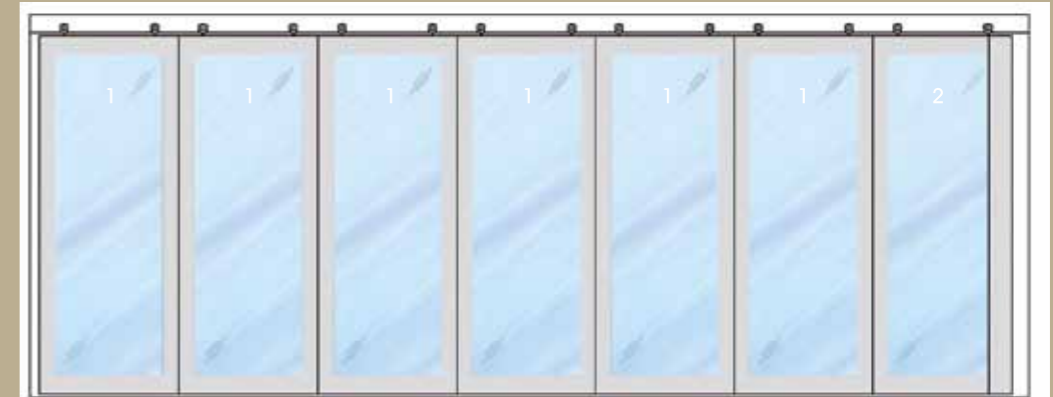

1 moViSTA Standard panel 2 moViSTA Lever closure panel

PANEL TYPES

ALL KEY DATA AT A GLANCE



- 1 Lever closure panels (TE) 3 Standard panel (NE) 5 Pass door – double-leaf (DTZ) 7 Fixed door (FT)
- 2 Corner panel (EE) 4 Pass door – single-leaf (DTE) 6 Window panel (FE)

TECHNICAL DETAILS

	Type 100	Type 100K	moVISTA
Panel thickness mm	113	100	100
Panel height max mm*	13000	13000	4000
Panel width max mm (recommended) 1320	1320	1320	1320
Panel width min mm (recommended)	650	650	650
Designs			
Track systems - max Weight/Panel	1-point - 400 KG / 2-point - 680 KG	1-point - 400 KG / 2-point - 680 KG	2 Pkt - 680 KG
Frames	Aluminum / steel	Aluminum / steel	Aluminum / steel
Surface boards / glass	16 / 19 mm	16 / 19 mm	ESG / VSG - 8 / 8,76 mm
Aluminum sections			
Vertical and horizontal Sections	E6 / EV1 anodized aluminum sections	E6 / EV1 anodized aluminum sections	E6 / EV1 eloxierte Aluminium-Profil
Sealing bars	Black anodized aluminum sections	Black anodized aluminum sections	Black anodized aluminum sections
Style	No visible aluminum sections	Visible aluminum sections (edge protection)	Visible aluminum sections (edge protection)
Operation	Manual / semi-automated	Manual / semi-automated	Semi-automated
Pass doors	Single- or double-leaf	Single- or double-leaf	Single- or double-leaf
	Fixed	Fixed	Fixed
	Stainless-steel fittings	Stainless-steel fittings	Stainless-steel fittings
Sound insulation (dB)	39-57 RwP	39-53 RwP	45 + 47 RwP

* 17530 mm already installed (WORLD TRADE CENTER, South Korea)

LOCKING SYSTEMS

SPEEDINESS + STABILITY

3-S Locking system

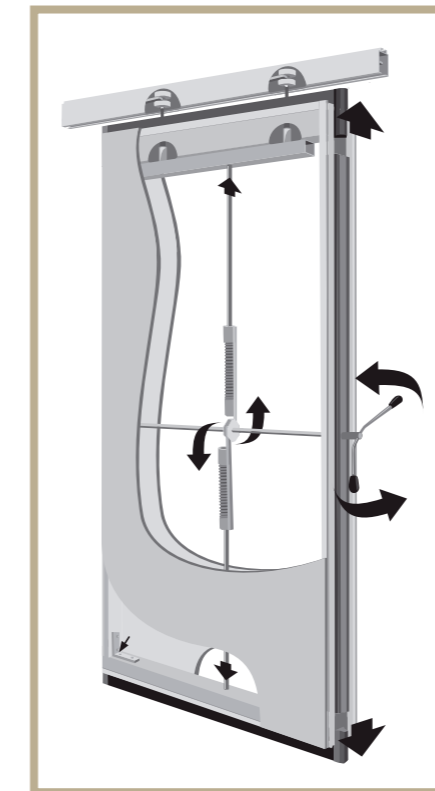

Quick-Set fastener enables opening or closing the panels with a mere half turn in only three seconds.

HUFCOR ESS

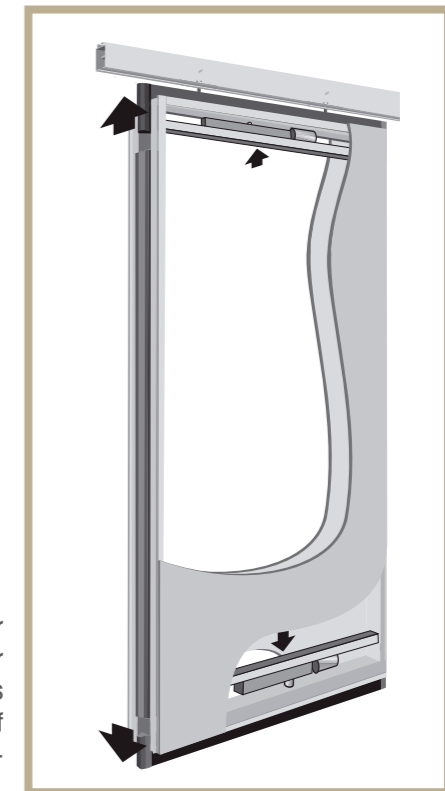

Microprocessor-controlled lifting motors for automated panel opening and closing.

SYSTEM SCHEMATIC SEMI-AUTOMATED ESS



- 1 Control box, incl. power pack & battery for emergency operation
- 2 Cabling, incl. shockproof plug, length 2m
- 3 Acoustic shielding of track system
- 4 Running gear casing (example)
- 5 Cabling 3x1,5mm², fastened to acoustic shielding
- 6 Key-operated switch integrated into wall mounting
- 7 Contact between wall mounting/panel
- 8 Running gear casing with inspection opening (example)
- 9 Shockproof socket, 230 VAC, 6A, max. 2m from Control box inside running gear casing (example)

HUFCOR G3000

A CLEAR VIEW - OPERABLE GLASS WALL PARTITIONS

Transparency which creates a desire for more – in shopping arcades, banks, hotels, restaurants, cafeterias and schools. We design your vision into reality, wherever you wish for operable glass walls for your clients or staff members.

Very stylish, slimline aluminum sections safely support glass panes with using four concealed bolts, providing the ultimate safety catch for the glass. Unlike friction supported systems, Hufcor's glasswall designs reduce the hazard of 'sliding panes'.

Hufcor G3000 operable glass wall offer many door options, such as fixed, self-shutting doors or movable 360° double doors. Design your wall to your specifications. Aesthetic mushroom-head end caps of cast aluminum provide connections between panels.

Tempered or laminated safety glass. Sand-blasted or sateen finish. Painted or printed. The choice is yours.

We offer precise angular joints or polygonal systems.. Hufcor utilizes our experience from numerous successfully completed projects at your disposal. Our glasswall consultants will visit your site and provide an overview of the multi-faceted design options with our operable glass wall partition G3000.

The G3000 system offers you excellent opportunities to present your products as well an openness and transparency that will be appreciated by your clients.



HUFCOR G3000

A CLEAR VIEW - OPERABLE GLASS WALL PARTITIONS

A large variety of options are available with Type G3000 operable glass wall partitions. The Type G3000 are contemporary architecture as the panels create transparency and open light transmittance, for shopping concourses, entertainment center, bank lobbies, hotels and restaurants.

Operable glass wall partitions enhance nearly every decor.

ATTACHMENT PARTS AND ACCESSORIES



Mushroom-head end caps and ball-bearing supported 360° door mechanism



Bottom bearing for fixed doors



Lateral and front-side panel-connecting floor catch



Bolt lock with PZ rosette and stainless-steel striking plate

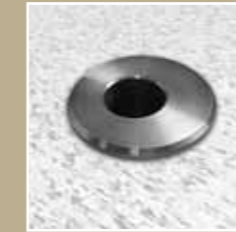

Eccentric stainless-steel floor sleeve



Horizontal brush section, top and bottom



Door stopper with integrated magnetic clamp



Vertical transparent plastic sealing strip clamp

END CAPS

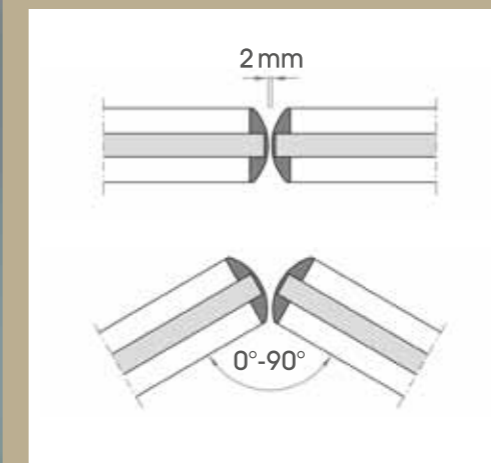

Mushroom-head injection molding end caps are particularly for polygonal partition systems

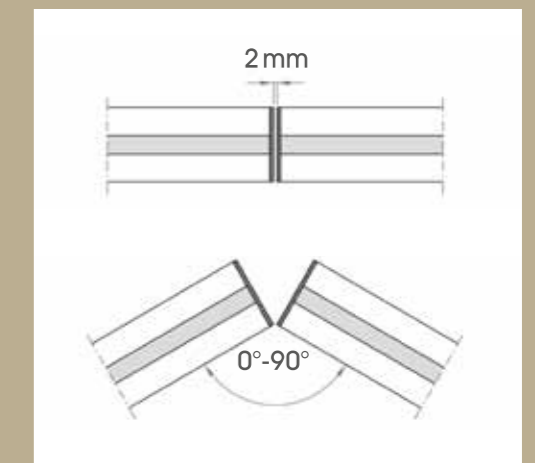

Flat stainless-steel end caps are form fitting transitions between aluminum sections

HUFCOR G3000

A CLEAR VIEW - OPERABLE GLASS WALL PARTITIONS



- Sliding panel
- Door panel
- 3 Anchor panel
- 4 Fixed door
- 360° Mechanism
- Bolt lock
- Floor-type door closer
- Flat AL handle
- Rod handle

Suspension	2-point (Type 36)
Suspended AL sections	I/L/T/U section
Parking systems	all 2-point parking positions
Glass thickness in mm	10 12
Panel width in mm	610...1250
Panel height in mm	...5200
Fixed door	Installation next to each fixed panel and at beginning or end of a partition
Pass width in mm	...1250
Displaceable pass door	Consisting of door panel and anchor panel
Door panel width in mm	Max. 900
Anchor panel width in mm	Door panel width + 320
Top clearance	20 mm
Bottom clearance	15 mm
Brush-type sealing	can be horizontally and vertically retrofitted
Panel locking	By bolting to floor and to each other
Section colors	Standard E6/EV1 / upon request: coating in all RAL colors
HUFCOR standard handle	FSB AL handle l=200mm
Profile cylinder size	PZ 30/30

HUFCOR G3000

PANEL CONFIGURATION

- ESG (tempered) and VSG (laminated) safety glass 10 mm and 12 mm
 - clear
 - sateen finish
 - colored
 - sand-blasted
 - printed
 - etched
- Glass edges beveled and polished
- 360° door mechanism for displaceable doors
- Combinable with fixed panels
- Upon request with vertical edge trims and horizontal brush-type trims
- High safety level (no friction clamping rails)
- No floor track
- 2-point roller system for easy movement
- Optional automatic floor-recessed door closer
- Panel-to-Panel floor locking as protection against forced opening and sliding
- TÜV tested

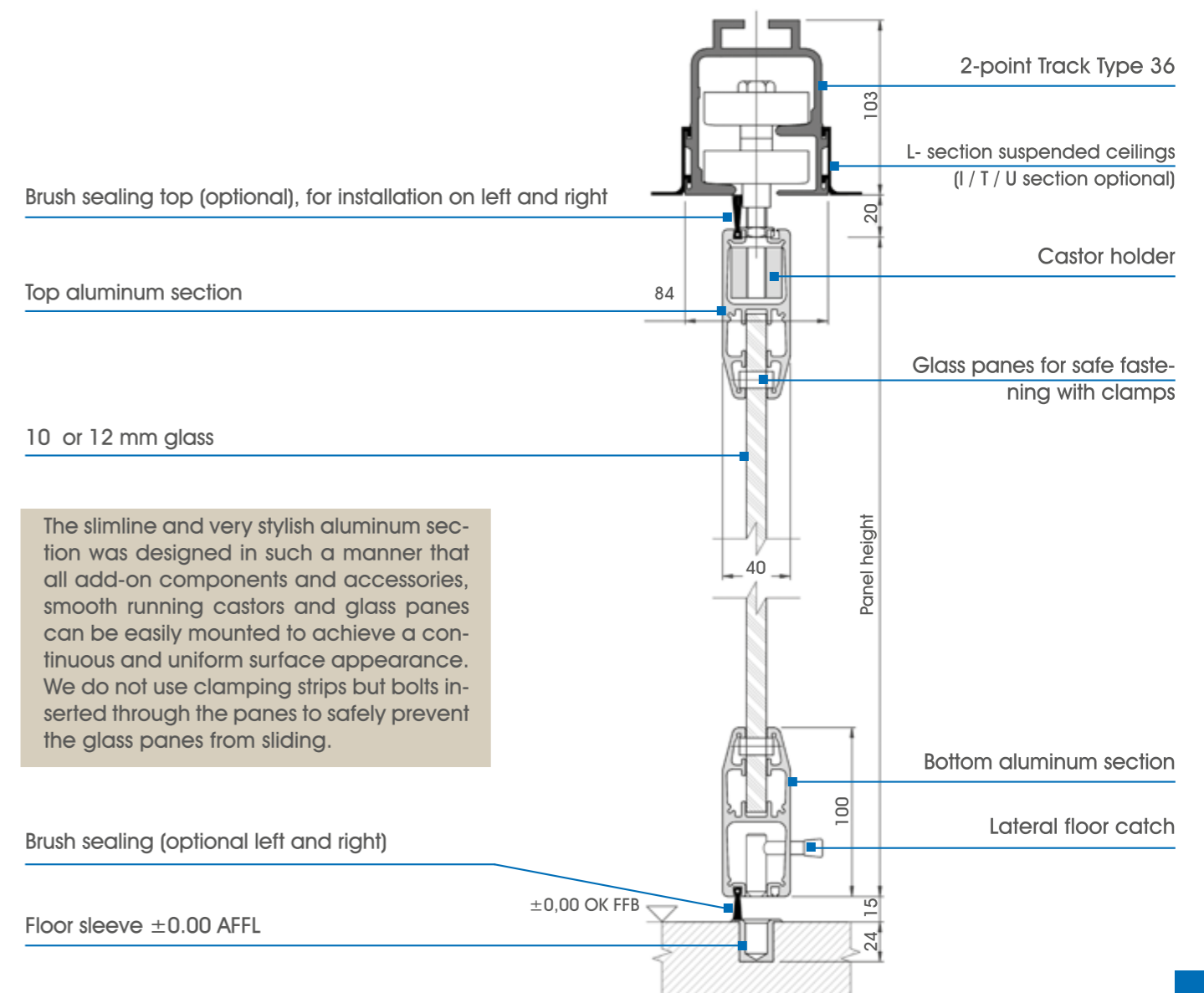

TRACK SYSTEMS EASY HANDLING – HIGH CONVENIENCE

We provide a perfect system of aluminum tracks that can be combined with freely selectable ceiling support sections and enables panel weights up to 680 KG. Special structurally tested suspension constructions for the track system ensure a high level of safety.

The combination of ball-bearing supported castors and high-quality, abrasion-proof plastic material guarantees an operational performance of more than 160 km. This corresponds to a service life of over 30 years at several operation cycles per day.



Two-point track
TYPE 36 to 450 kg
per panel



One-point track
TYPE 38 to 180 kg
per panel



One-point track
TYPE 40 to 400 kg
per panel



Two-point track
TYPE 57 up to 680 kg
per panel



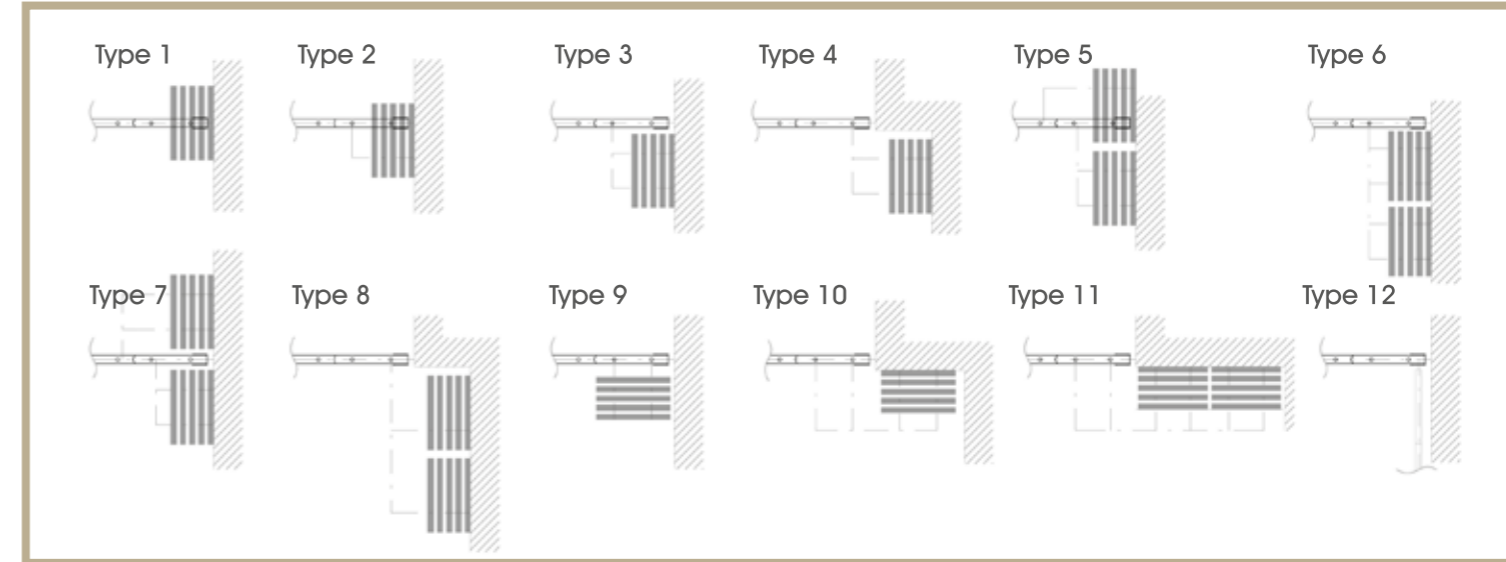
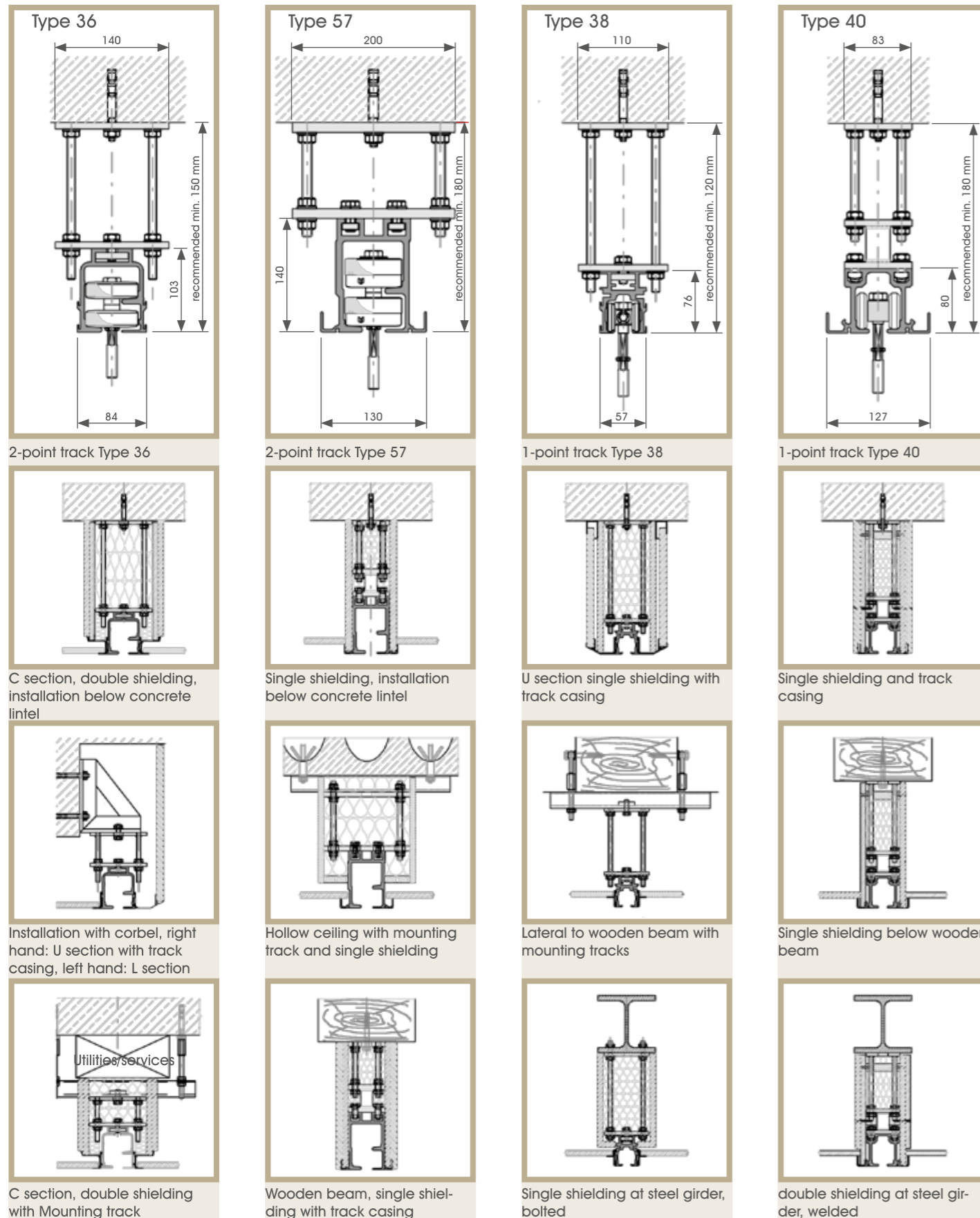

SCHEMATIC DIAGRAM NICHE DOORS

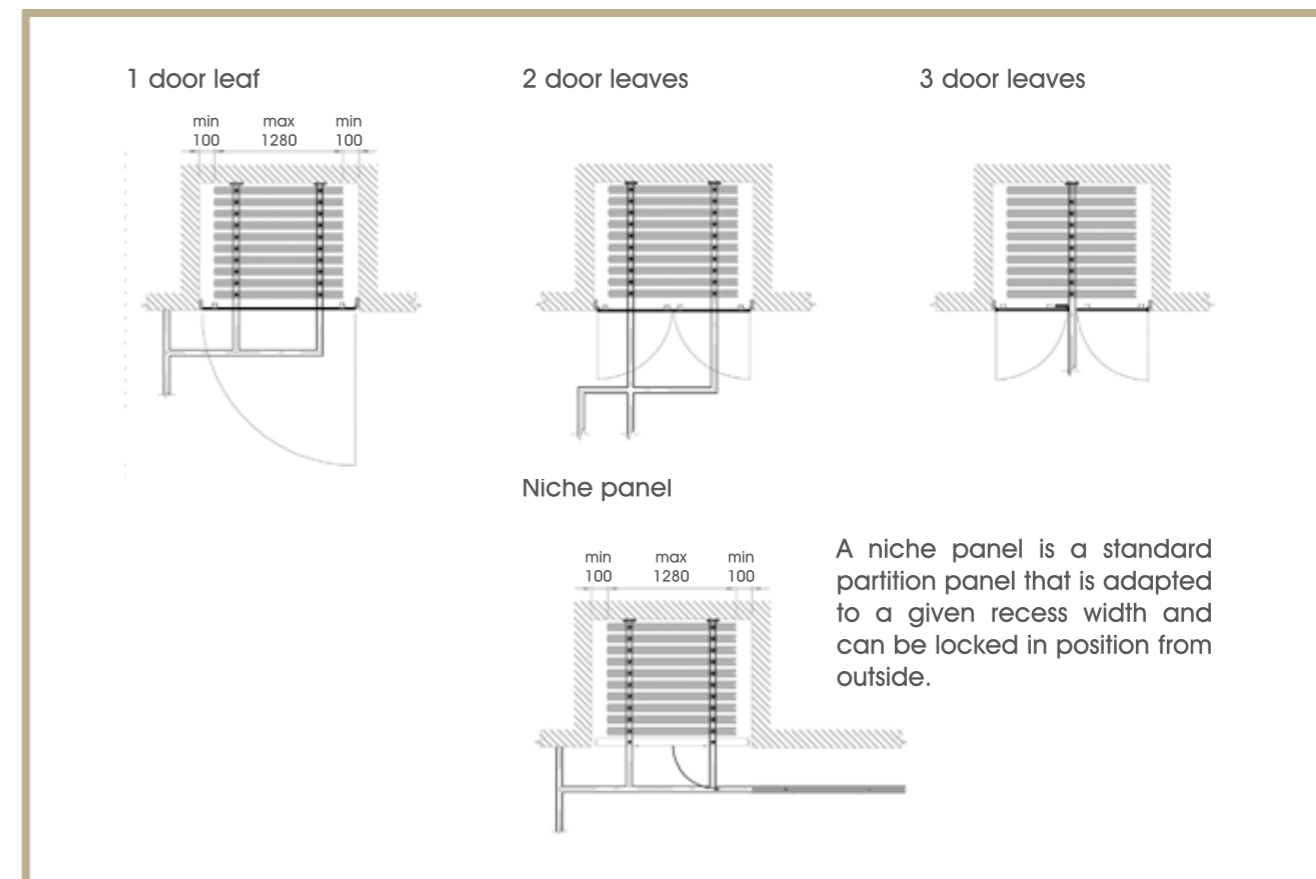

SURFACES

LARGE VARIETY OF FINISHES FOR CUSTOMIZED DESIGN

Hufcor's wide of range of available partition surfaces provides an unlimited degree of freedom for individual design solutions. Partition walls thus become style elements. Subtle or rich colors, matter-of-fact or natural character, purposeful or precious coating – our assortment of surface finish options will accommodate your every wish. Let your imagination fly! We will have the suitable decor for your project.

Surfaces of real wood, acoustic, digital print, mirror or sheet steel, or clad with carpet, wall-paper or cloth, or magnet-adhering, projectable and writable – we can design out-of-the-ordinary customer requests along with our standard offerings.



Mirror surface



Laminate surface



Cloth in veneer



Digital print



Wall-paper, cloth



Real wood veneer

SURFACES

REAL WOOD VENEER, ACOUSTIC SURFACES



REAL WOOD VENEER

Each real wood veneer is a valuable naturally grown unique specimen that gives an individual character to operable partitions. Hufcor applies only the highest quality veneers.

The range of colors stretches from light birch veneer via reddish, vivacious cherry wood veneer, dark walnut to almost black wenge veneer. Up to 20 plates can be combined, depending on the type of wood. The high-quality veneers are typically custom designed, patterned matched and protected with UV acrylic enamel. Aesthetically pleasing and ultra durable.



ACOUSTIC SOUND-ABSORBING SURFACES

Contemporary architecture is very fond of using various reverberant materials, such as stone, concrete, glass and aluminum; hence, it is often necessary to employ sound absorbers to attain pleasant room acoustics.

Such sound-absorbing systems do not only have to fulfill technical requirements but also leave some leeway for architectural design. Acoustic surfaces may be perforated or slotted to absorb sound, but still maintain the acoustical functionality of the operable wall.

SCHEMATIC DIAGRAM – PERFORATED BOARD

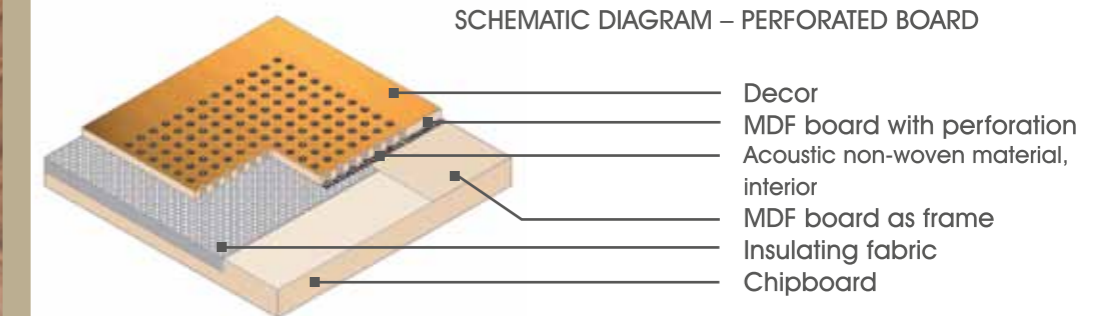

Slotted acoustic boards

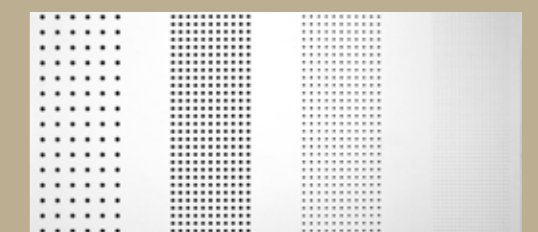

Different perforation sizes

CERTIFICATION / REPRESENTATIVE PROJECTS VERIFIED QUALITY

Auszug aus der HUFCOR Deutschland GmbH Referenzliste (Stand 10/2012)

Segment	Beschreibung	Anzahl
Kommerzielle Gebäude	Bürogebäude, Industrie, Handel, Dienstleistung, Flughäfen, Forschungseinrichtungen, Karzeilen	698
Medizinische Einrichtungen	Krankenhäuser, Pflegeheime, Arztpraxen	271
Einkaufszentren	Glastrennwände	85
Hotels, Restaurants	Konferenzsäle, Jugendherbergen, Gastronomie	152
Öffentliche Einrichtungen	Rathäuser, Ämter, Justiz, Feuerwehr, Polizei, Bundeswehr, Messe	349
Bildungseinrichtungen	Universitäten, Schulen, Kindereinrichtungen	595
Sport und Veranstaltung	Sportstätten, Stadien, Tanzschulen, Bäder	144
Religiöse Einrichtungen	Kirchen, Gemeindezentren, Klöster, Pfarrheime	205
Kreditinstitute	Banken und Sparkassen, Versicherungen	86
GESAMT:		2585

Projekte im europäischen Ausland
Im europäischen Ausland wurden bisher **1.538** Projekte und Großprojekte realisiert.

EG-Konformitätserklärung nach EG-Richtlinie 2006/42/EG (Maschinenrichtlinie)

HUFCOR Deutschland GmbH
Triftweg 34
06847 Dessau-Roßlau

gegen genannte Produkt
Mobiles Trennwandsystem mit
elektromechanischer Verriegelung
Typ 100/100K ESS

Richtlinie 2006/42/EG über Maschinen
in Verbindung mit der 9. ProdsV
(Maschinenverordnung)

DIN EN ISO 12100, DIN EN ISO 13849-1,
DIN EN 1088, DIN EN 60204-1, DIN
31000

Fraunhofer Institut für Bauphysik
hinsichtlich des Schalldämmmaßes
nach DIN EN 12140-3 bis 54 dB,
PÜZ MFPA Leipzig hinsichtlich des
Schalldämmmaßes nach DIN EN
20140-3 - 57 dB,
PÜZ MFPA Leipzig hinsichtlich des
Feuerwiderstandes nach DIN EN
13501-2 als EI 30 und
TÜV SÜD hinsichtlich der Ballwurf-
sicherheit nach DIN 18032-3

Reiko Lehmann

Präqualifikation HUFCOR (Deutschland) GmbH Triftweg 34 06847 Dessau

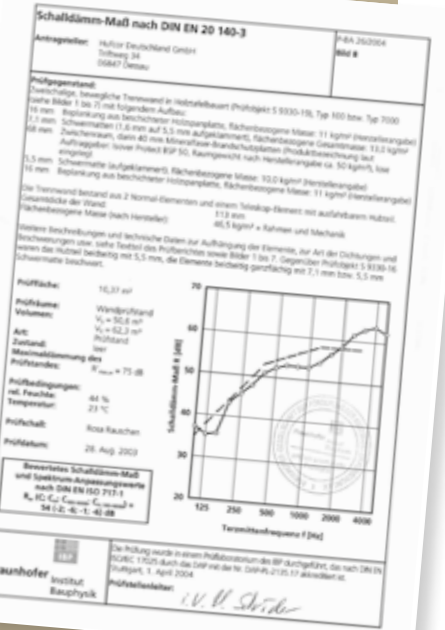

ZERTIFIKAT TUV NORD

Nr.: B 04 04 20546 002

Zertifikatsträger:
Produkt:
Modell:
Kerndaten:
Geprüft nach:
Zertifikat-Nr.:

HUFCOR Deutschland GmbH
Triftweg 34
06847 Dessau-Roßlau
Deutschland

Mobile Trennwände
Typ 992 und Typ 7700,
Typ 933K und Typ 7000

Typ 992 und 7700:
Bauhöhe: 175 mm
Bauhöhe: 220 mm
Bauhöhe: 300 mm
Bauhöhe: 350 mm
Bauhöhe: 400 mm
Bauhöhe: 450 mm
Bauhöhe: 500 mm
Bauhöhe: 550 mm
Bauhöhe: 600 mm
Bauhöhe: 650 mm
Bauhöhe: 700 mm
Bauhöhe: 750 mm
Bauhöhe: 800 mm
Bauhöhe: 850 mm
Bauhöhe: 900 mm
Bauhöhe: 950 mm
Bauhöhe: 1000 mm

Typ 933K und 7000:
Bauhöhe: 100 mm
Bauhöhe: 150 mm
Bauhöhe: 200 mm
Bauhöhe: 250 mm
Bauhöhe: 300 mm
Bauhöhe: 350 mm
Bauhöhe: 400 mm
Bauhöhe: 450 mm
Bauhöhe: 500 mm
Bauhöhe: 550 mm
Bauhöhe: 600 mm
Bauhöhe: 650 mm
Bauhöhe: 700 mm
Bauhöhe: 750 mm
Bauhöhe: 800 mm
Bauhöhe: 850 mm
Bauhöhe: 900 mm
Bauhöhe: 950 mm
Bauhöhe: 1000 mm

ZERTIFIKAT TUV

Nr.: B 04 05 20546 003

Zertifikatsträger:
Produkt:
Modell:
Kerndaten:
Geprüft nach:
Zertifikat-Nr.:

HUFCOR Deutschland GmbH
Triftweg 34
06847 Dessau-Roßlau
Deutschland

Mobile Trennwände
Typ O 3000

Typ O 3000:
Bauhöhe: 3000 mm
Bauhöhe: 3200 mm
Bauhöhe: 3400 mm
Bauhöhe: 3600 mm
Bauhöhe: 3800 mm
Bauhöhe: 4000 mm
Bauhöhe: 4200 mm
Bauhöhe: 4400 mm
Bauhöhe: 4600 mm
Bauhöhe: 4800 mm
Bauhöhe: 5000 mm
Bauhöhe: 5200 mm
Bauhöhe: 5400 mm
Bauhöhe: 5600 mm
Bauhöhe: 5800 mm
Bauhöhe: 6000 mm

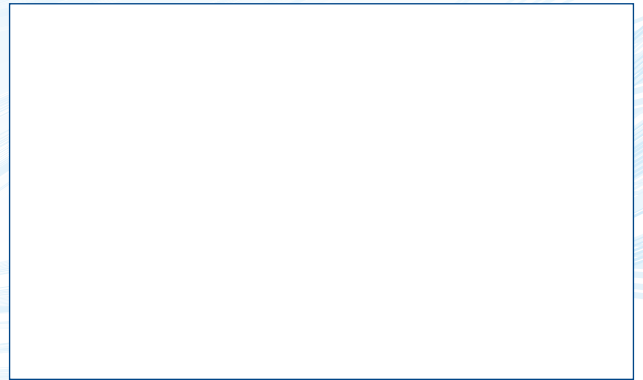

www.hufcor.de

