

Programmable pressure and temperature transmitters

PTM/RS485



Version: 28.03.2012

Technical Specifications

Pressure measuring range (bar)

	0.1 ... 0.5	> 0.5 ... 2	> 2 ... 25
Overpressure	3 bar	3 x FS (≥ 3 bar)	3 x FS
Burst pressure	> 200 bar	> 200 bar	> 200 bar
Accuracy, (3), (\pm % FS)	≤ 0.25	≤ 0.1	≤ 0.1
Thermal shift, (\pm % FS/$^{\circ}$C)			
Zero point 0...70 $^{\circ}$ C	≤ 0.06	≤ 0.03	≤ 0.015
Zero point -25...85 $^{\circ}$ C	≤ 0.08	≤ 0.04	≤ 0.02
Span 0...70 $^{\circ}$ C	≤ 0.015	≤ 0.015	≤ 0.015
Span -25...85 $^{\circ}$ C	≤ 0.02	≤ 0.02	≤ 0.02
Total Error, (4), (5), (\pm % FS)			
-10...50 $^{\circ}$ C, (typ. / max.)	$\leq 0.15 / 0.3$ (≤ 200 mbar: 0.3 / 0.6)	$\leq 0.15 / 0.3$	$\leq 0.15 / 0.3$
-25...85 $^{\circ}$ C, (typ. / max.)	$\leq 0.65 / 0.7$ (≤ 200 mbar: 0.65 / 0.8)	$\leq 0.65 / 0.7$	$\leq 0.55 / 0.7$
Long term stability, (6)	< 0.5% FS / < 4 mbar	< 0.2% FS / < 4 mbar	< 0.1% FS / < 0.2% FS

	> 25 ... 600, (1), (2)	> 600 ... 1000, (1)
Overpressure	3 x FS ($\leq 850 / \leq 1500$ bar)	1500 bar
Burst pressure	> 850 / ≤ 1500 bar	> 1500 bar
Accuracy, (3), (\pm % FS)	≤ 0.1	≤ 0.25
Thermal shift, (\pm % FS/$^{\circ}$C)		
Zero point 0...70 $^{\circ}$ C	≤ 0.015	≤ 0.015
Zero point -25...85 $^{\circ}$ C	≤ 0.02	≤ 0.02
Span 0...70 $^{\circ}$ C	≤ 0.015	≤ 0.015
Span -25...85 $^{\circ}$ C	≤ 0.02	≤ 0.02
Total Error, (4), (5), (\pm % FS)		
-10...50 $^{\circ}$ C, (typ. / max.)	$\leq 0.15 / 0.3$	n.a.
-25...85 $^{\circ}$ C, (typ. / max.)	$\leq 0.55 / 0.7$	n.a.
Long term stability, (6)	< 0.1% FS / < 0.2% FS	< 0.1% FS / < 0.2% FS

(1) Titanium available ≤ 400 bar (burst pressure > 550 bar)

(2) Overpressure and burst pressure 1500 bar (stainless steel) optional

(3) Zero based accuracy according to DIN16086, incl. hysteresis and repeatability at ambient temperature

(4) Total error including accuracy and temperature influences at maximum signal span (16 mA)

(5) Active compensated, ≤ 100 bar

(6) 1 year (typ. / max.), the long term stability can be improved by ageing (burn-in) the sensor

Temperature measuring range

Standard, (1), (2)	-10...50 $^{\circ}$ C
Lower end of range, (2)	-25 $^{\circ}$ C
Upper end of range, (2)	85 $^{\circ}$ C
Accuracy	$\leq \pm 2$ $^{\circ}$ C

(1) Available active compensated only

(2) Depending on temperature range of the active compensation

Temperature range

Operating temperature	-25...85 °C
Process temperature	-40...150 °C
Storage temperature	-25...85 °C

Electrical specifications

Output	
Digital	RS485
Protocol	Modbus RTU
Analog	4...20 mA
Resolution	
Digital output	0.01% FS
Analog output	0.025% FS
Output adjustable	
4 mA	-5% FS...105% FS
20 mA	-5% FS...105% FS
Span	25% FS...110% FS (≥ 50 mbar)
Low pass filter	0.1 / 1 / 10 / 30 Hz (standard: 30 Hz)
Power supply	9...30 V DC
Supply influence	< 0.1% FS
Circuit diagram	
Load resistance	
Load influence	< 0.1% FS

Qualifications

	Description	Level	Typical interferences
EN 60068-2-6	Vibration	4g (4...100 Hz / ± 3.2 mmpp)	
EN 60068-2-27	Shock	100g (impulse duration 6 ms)	
EN 55022	Emission, class B	< 30 dBμV/m (0.03...1 GHz)	
EN 61000-4-2	Electrostatic discharge	4 kV contact 8 kV air	
EN 61000-4-3	Irradiated RF	10V/m (0.08...1 GHz)	Radio sets, wireless phones
EN 61000-4-4	Transients (burst)	2 kV	Motors, valves
EN 61000-4-5	Surge	10 kA (8 / 20 μs), (1)	Lightning
EN 61000-4-6	Conducted RF	10 V (0.15...80 MHz)	Frequency converters

(1) Only with optional surge (lightning) protection

Physical specifications

Materials	
Transducer	Stainless steel (316L / 1.4435), titanium (Gr. 2), (1)
Housing	Stainless steel (316L / 1.4404), titanium (Gr. 2)
Seals	Viton (Standard), EPDM, Kalrez
Cable	PUR, PTFE, PE

(1) Hastelloy (C-276) on request

Equipment

Overview

10.00.0091	Accessories overview

Interface

101138	PTM - Interface

Software

101224	PC Software V1.50

Additional documents

Manuals

	Article number	Description
10.00.0079	DEB003	Configuration software
10.00.0089	DEB005	User manual

Operating and safety instructions

	Article number
10.00.0137	DMM009

Ordering information

		X. XXXX.	XXXX.	XX.	XXX
Type	PTM/RS485	43			
Pressure type	Gauge	1			
	Absolute (vacuum)	2			
	Sealed gauge	3			
Pressure measuring range	Any pressure measuring ranges between 0...100 mbar and 0...1000 bar available, (1), (2)	XX			
Process connection	G 1/4 F, (Fig. 1)	00			
	G 1/4 M, (Fig. 2)	11			
	G 1/4 M, manometer DIN 16288, (Fig. 3)	12			
	G 1/2 M, (Fig. 4)	13			
	G 1/2 M, frontal diaphragm, (Fig. 5)	14			
	G 1/2 M, flush diaphragm, (Fig. 6)	15			
	G 1/2 M, manometer DIN 16288, (Fig. 7)	16			
	1/4 NPT M	10			
	1/2 NPT M, (Fig. 8)	19			
	Customized connection available	XX			
Electrical connection	Binder 723, 7-pin, IP 67, (Fig. 10), (3)		04		
	MIL C26482, 10-6, IP 40, (Fig. 11), (3)		06		
	PE cable, IP 67, (Fig. 12), (4), (5)		13		
	PUR cable, IP 67, (Fig. 12), (4), (6)		15		
	PTFE cable, IP 67, (Fig. 12), (4)		21		
	PVC cable, blue, IP 67 (Fig. 12), (9)		14		
	Customized connection available		XX		
Output signal	RS485 / 4...20mA (pressure)		62		
	RS485 / 4...20 mA (pressure) with surge protection		64		
	RS485 / 4...20mA (pressure and temperature)		65		
	RS485 / 4...20mA (pressure and temperature) with surge protection		66		
Accuracy	$\leq \pm 0.25$ % FS (≤ 500 mbar / > 600 bar)			1	
	$\leq \pm 0.1$ % FS (> 500 mbar...600 bar)			2	
Temperature range	0...70 °C compensated (allowed process temperature: 0...80 °C)			0	
	-25...85 °C compensated (allowed process temperature: -25...100 °C)			1	
Option 1	Throttle, (7)				A
	Special oil filling: ASEOL Food (for food applications)				G
	Special oil filling: Halocarbon (for oxygen applications), (8), (10)				H
Option 2	Electronics packed in gel: Gauge pressure				C
	Electronics packed in gel: Absolute pressure				D
Option 3	Active compensated (≤ 100 bar)				E
	Version titanium				K

Seals: Viton (standard)					U
Seals: EPDM					S
Seals: Kalrez					T
Seals: NBR					H
Ageing					Z

- (1) Titanium available \leq 400 bar (burst pressure > 550 bar)
- (2) mbar, PSI, kPa etc. available
- (3) Cable socket connector not included
- (4) Please specify the required cable length and medium
- (5) Suitable for drinking water (food approved)
- (6) For operating temperature > 50°C, PE or PTFE cable must be used
- (7) Only with pressure connection Fig. 2, Fig. 3, Fig. 4, Fig. 7 and Fig. 8
- (8) Maximum pressure measuring range \leq 270 bar (burst pressure > 400 bar)
- (9) ACS Certification
- (10) min. Medium temperature -25 ° C

Technical drawings

Process Connection

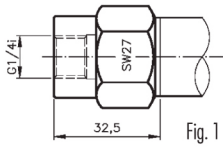

Fig. 1

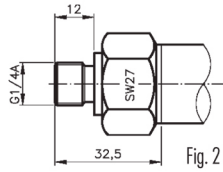

Fig. 2

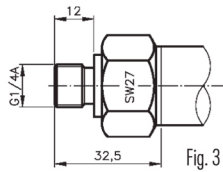

Fig. 3

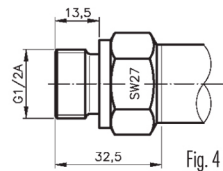

Fig. 4

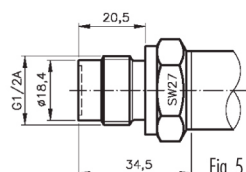

Fig. 5

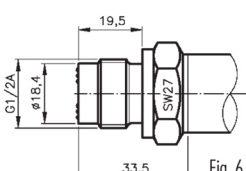

Fig. 6

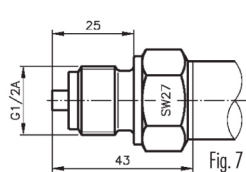

Fig. 7

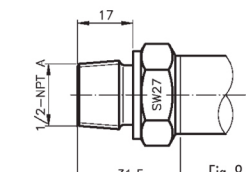
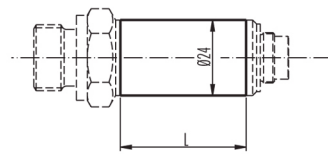

Fig. 8

Dimensions

Version for medium temperature up to 100°C



L = 94 mm, with overvoltage protection = 195 mm

Version for medium temperature up to 150°C

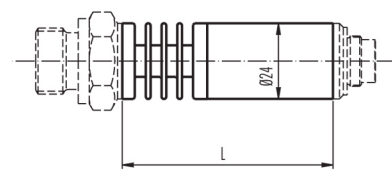

L = 121 mm, with overvoltage protection = 222 mm

Electrical Connection

Fig. 10

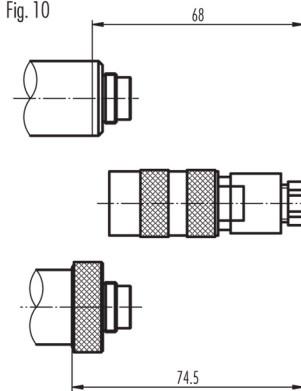

View to cable socket connector



Pin	RS485
1	Pout
2	Tout
3	+Vin
4	GND
5	
6	A
7	B

Fig. 11

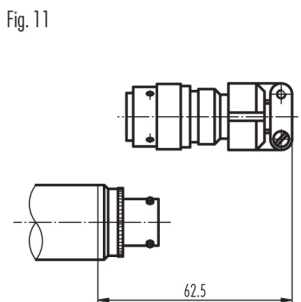

View to cable socket connector



Pin	RS485
A	+Vin
B	GND
C	Pout
D	Tout
E	A
F	B

Fig. 12

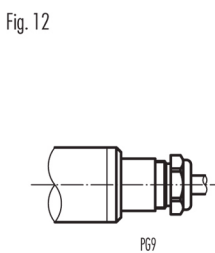

Colour	RS485
white	+Vin
yellow	GND
brown	Pout
pink	Tout
green	A
grey	B

Specifications may change without notice.

STG Great Britain:

STG Great Britain Ltd.
Higham Dairy Farm, Bumphill Lane, Alfreton | Derbyshire | Great Britain, DE55 6AH
contact@stssensors.com | www.stssensors.co.uk

STG Headquarters, Switzerland:

STG Sensor Technik Sirmach AG
Rüthhofstrasse 8, 8370 Sirmach, Switzerland
sales@stssensors.com | www.stssensors.com

STG France:

STG France
844 Route de la Caille, 74350 Allonzier la Caille, France
info-fr@stssensors.com | www.stssensors.fr

STG Germany:

STG Sensoren Transmitter Systeme GmbH
Poststrasse 7, 71063 Sindelfingen, Germany
info-de@stssensors.com | www.stssensors.de

STG Italy:

STG Italia s.r.l.
Via Gesù 5, 20090 Opera (Milano), Italy
info-italia@stssensors.com | www.stssensors.it