

Submersible level and temperature transmitters

ATM/N/T



Version: 28.03.2012

Technical Specifications

Pressure measuring range (mH2O)

	1 ... 5, (1)	> 5 ... 20	> 20 ... 250
Overpressure	3 bar	3 x FS (min. 3 bar)	3 x FS
Burst pressure	> 200 bar	> 200 bar	> 200 bar
Accuracy, (2), (\pm % FS)	$\leq 0.5 / \leq 0.25$	$\leq 0.5 / \leq 0.25 / \leq 0.1$	$\leq 0.5 / \leq 0.25 / \leq 0.1$
Thermal shift, (\pm % FS/$^{\circ}$C)			
Zero point -5...50 $^{\circ}$ C	≤ 0.06	≤ 0.03	≤ 0.03
Span -5...50 $^{\circ}$ C	≤ 0.015	≤ 0.015	≤ 0.015
Response time, (typ.)	< 1ms / 10...90% FS	< 1ms / 10...90% FS	< 1ms / 10...90% FS
Long term stability, (3)	< 0.5% FS / < 4 mbar	< 0.2% FS / < 4 mbar	< 0.1% FS / < 0.2% FS

(1) 0.5 mH2O on request

(2) Zero based accuracy according to DIN16086, incl. hysteresis and repeatability at ambient temperature

(3) 1 year (typ. / max.), the long term stability can be improved by ageing (burn-in) the sensor

Temperature measuring range

Standard, (1)	-5...80 $^{\circ}$ C
Lower end of range	-25 $^{\circ}$ C
Upper end of range	85 $^{\circ}$ C
Temperature span	> 30 $^{\circ}$ C
Accuracy, (2)	
0...70 $^{\circ}$ C, (typ. / max.)	$\pm 0.5 / 1.0$ $^{\circ}$ C
-25...85 $^{\circ}$ C, (typ. / max.)	$\pm 1.0 / 1.5$ $^{\circ}$ C

(1) Other temperature measuring ranges on request

(2) Probe, electronics, calibration

Temperature range

Operating temperature	-5...80 $^{\circ}$ C
Process temperature	-5...80 $^{\circ}$ C
Storage temperature	-10...80 $^{\circ}$ C

Electrical specifications

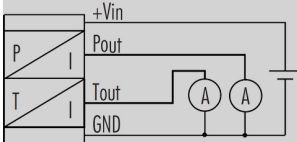
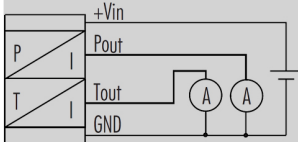
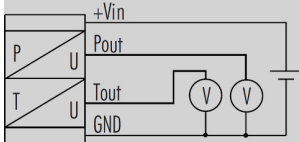
	4 ... 20 mA	0 ... 20 mA	0 ... 5 V / 0 ... 10 V
Power supply	15...30 V DC	15...30 V DC	15...30 V DC
Supply influence	< 0.1% FS	< 0.1% FS	< 0.1% FS
Current consumption			3 mA
Circuit diagram			
Load resistance	$(U_b - 5V) / 0.02A$	$(U_b - 5V) / 0.02A$	$R_L > 10k\Omega$
Load influence	< 0.1% FS	< 0.1% FS	< 0.1% FS

Qualifications

	Description	Level	Typical interferences
EN 61000-4-2	Electrostatic discharge	4 kV contact 8 kV air	
EN 61000-4-3	Irradiated RF	10V/m (0.08...1 GHz, 3s)	Radio sets, wireless phones
EN 61000-4-4	Transients (burst)	2 kV	Motors, valves
EN 61000-4-6	Conducted RF	10 V (0.15...80 MHz, 3 s)	Frequency converters

Physical specifications

Materials	
Transducer	Stainless steel (316L / 1.4435), titanium (Gr. 2), (1)
Housing	Stainless steel (316L / 1.4404), titanium (Gr. 2)
Seals	Viton (Standard), EPDM, Kalrez
Cable	PUR, PTFE, PE

(1) Hastelloy (C-276) on request

Equipment

Overview

10.00.0091	Accessories overview

Additional documents

Operating and safety instructions

	Article number
10.88.0092	DMM029

Ordering information

		X. XXXX.	XXXX.	XX.	XXX
Type					
	ATM/N/T	31			
Pressure type					
	Gauge	1			
	Absolute (vacuum)	2			
Pressure measuring range					
	Any pressure measuring ranges between 0...1 mH ₂ O and 0...250 mH ₂ O available, (1), (2)	XX			
Process connection					
	Closed, (Fig. 1)		55		
	Open, (Fig. 2)		56		
	Customized connections available		XX		
Electrical connection					
	Connectable version, IP 68, (Fig. 4), (3)			07	
	PE cable, IP 68, (4), (5)			13	
	PUR cable, IP 68, (4), (6)			15	
	PTFE cable, IP 68, (4)			21	
	Customized connection available			XX	
Output signal					
	4...20 mA			05	
	0...20 mA			00	
	0...5 V DC			46	
	0...10 V DC			47	
Accuracy					
	≤ ± 0.5 % FS				0
	≤ ± 0.25 % FS				1
	≤ ± 0.1 % FS (on request)				2
Temperature range					
	-5...50 °C compensated (allowed process temperature: -5...50 °C)				4
	-5...80 °C compensated (allowed process temperature: -5...80 °C)				5
Option 1					
	Special oil filling: ASEOL Food (for food applications)				
	Special oil filling: Halocarbon (for oxygen applications) (7)				
Option 2					
	Electronics packed in gel: Gauge pressure				C
	Electronics packed in gel: Absolute pressure				D
Option 3					
	Ballast weight				B
	Version titanium				K
	Seals: Viton (standard)				U
	Seals: EPDM				S
	Seals: Kalrez				T
	Aging				Z

(1) 0.5 mH₂O on request

(2) mH₂O, mWS, mWC etc. available

(3) Connector with required cable has to be ordered separately (KART100)

(4) Please specify the required cable length and medium

(5) Suitable for drinking water (food approved)

- (6) For operating temperature $> 50^{\circ}\text{C}$, PE or PTFE cable must be used
- (7) min. Medium temperature -25°C

Technical drawings

Dimensions

Fig. 1: Closed version

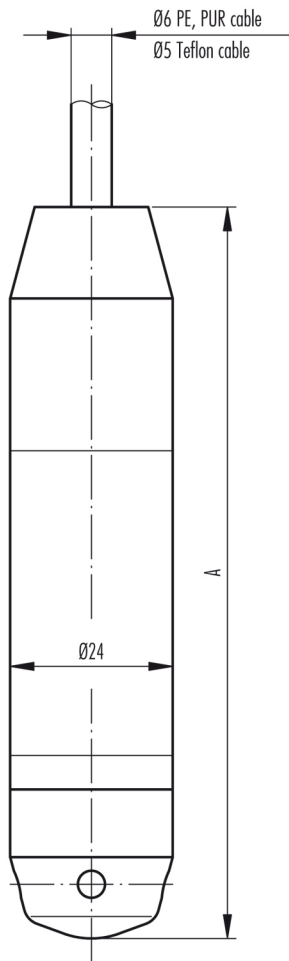

Fig. 2: Open version

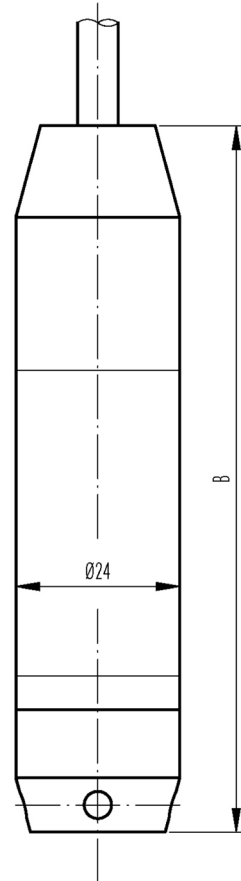

Fig. 3: with process connection

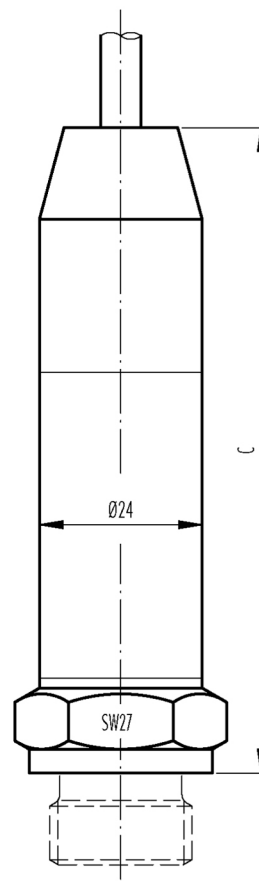
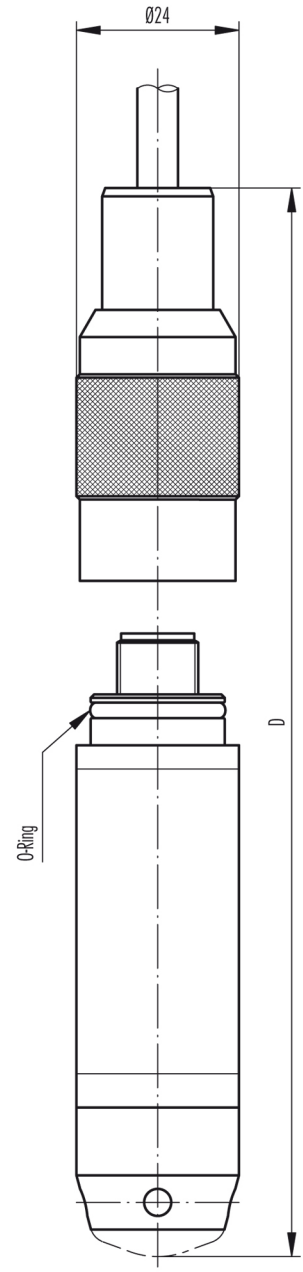

Fig. 4: Electrical connection, connectable



Standard

	A [mm]	B [mm]	C [mm]	D [mm]	Weight [g]
without ballast weight	137	133	on request*	on request*	approx. 180
with ballast weight	224	220	on request*	on request*	approx. 440

*C: depending on process connection

*D: depending on process connection or version

Colour 4-Wire

white +Vin
yellow GND
brown Pout
green Tout



Specifications may change without notice.

STG Great Britain:

STG Great Britain Ltd.
Higham Dairy Farm, Bumhill Lane, Alfreton | Derbyshire | Great Britain, DE55 6AH
contact@stssensors.com | www.stssensors.co.uk

STG Headquarters, Switzerland:

STG Sensor Technik Sirmach AG
Rüthofstrasse 8, 8370 Sirmach, Switzerland
sales@stssensors.com | www.stssensors.com

STG France:

STG France
844 Route de la Caille, 74350 Allonzier la Caille, France
info-fr@stssensors.com | www.stssensors.fr

STG Germany:

STG Sensoren Transmitter Systeme GmbH
Poststrasse 7, 71063 Sindelfingen, Germany
info-de@stssensors.com | www.stssensors.de

STG Italy:

STG Italia s.r.l.
Via Gesù 5, 20090 Opera (Milano), Italy
info-italia@stssensors.com | www.stssensors.it